

BACCALAURÉAT GÉNÉRAL

SESSION 2011

ANGLAIS

LANGUE VIVANTE 1

Séries ES - S

DURÉE DE L'ÉPREUVE : 3 heures - COEFFICIENT : 3

L'usage de la calculatrice et du dictionnaire n'est pas autorisé.

Dès que ce sujet vous est remis, assurez-vous qu'il est complet.
Ce sujet comporte 4 pages numérotées de 1/4 à 4/4.

Répartition des points

Compréhension	10 points
Expression	10 points

The Estrada Brothers don't know how to read or write. They're Mexican peasants with a very modest income based on fishing for *tilapia* in a local dam, harvesting *chiles* or onions as day laborers on private farms or growing corns, with little luck, on communal land. I've known them for almost 30 years. [. . .]

5 The Estradas are generous and joyful, some of the best people I've ever met. I've watched their children grow up, as well as some of their grandchildren.

Many of them I met once and never saw again: They emigrated to the United States and haven't returned. But that doesn't mean they haven't wanted to return; for many it is simply too risky. [. . .]

10 Throughout these 30 years, I've known about the realities of immigration through these friends who are so close to me. I've seen them go mad with jealousy. While they sometimes work two consecutive shifts to send money to their wives, they don't know if they're being cheated on or if their wives are spending their money with another man. It is an act of faith to send money every month – for years – to a family they only know about over the phone or through photographs. They drink and smoke until the pain is anaesthetized.

15 I've also seen the wives stay behind without knowing if the fathers of their children, the men they love, will ever come back. They can't know for sure if their husbands have started a new family on the other side of the border. Sitting at the dinner table, they become lost in their thoughts as they try to imagine the distant world where their men live. Men and women, both, end up wrecked by jealousy, doubt and the uncertainty of love.

20 I've seen them crying in the fields, staring at the horizon, because for months they haven't heard a thing from those who decided to cross over to the other side. This was the case of Rosa, my friend Pedro's wife, who disappeared for a long while. They knew Rosa would cross the river tied to the inner tube of a tractor's tire, pulled by ropes. That's what the "pollero" – the smuggler hired to get her across – had explained to them. They also knew that Rosa didn't know how to swim.

Desperate Pedro and his children looked through list upon list of Mexicans who had died while attempting to cross the river. Their search was in vain. Nothing. No trace of Rosa, no trace of the "pollero."

30 Pedro couldn't stand the sadness. He prayed, he begged God, the saints. He promised not to cut his hair until she returned. Rosa appeared eight months later. Safe and sound. And frightened. She had been arrested and incarcerated. She tried to cross the border with fake papers, which is a crime. She was kept in jail for seven months. She couldn't tell anyone. Despite the risk of a longer prison sentence if she's caught, she still plans to try it again. She wants a better life. The last time I saw him, Pedro's hair was still long. He looked like a hippie.

35 None of the Estradas speak English. But they've managed. Pedro, who left for five years, befriended his boss, who spoke no Spanish, just through signs. For entire afternoons, they sat down and talked about their families, their worries, their hobbies. And they understood each other.

40 Lucio's son Pedro married an American girl – a soldier who fought in Iraq and doesn't speak Spanish. Pedro's children were born and grew up in the United States. They only recently met their grandparents, Lucio and Evelia. It was hard for them to communicate. That language barrier. The grandkids can barely babble Spanish.

45 This, then, is when the problem of illegal immigration ceases to be a legal one and becomes a political, social and even moral question. Human lives are at stake. The lives of people who fall in love, pray, laugh, love their children, suffer and forgive. It is for good people, like the Estradas, that the terrible matter of immigration must be confronted – in the United States or any other country that depends on migrant labor. Not doing so is inhuman. [. . .]

Adapted from Guillermo Arriaga, "My friends, the illegal immigrants" in the *Financial Times*, April 11, 2009

NOTE AUX CANDIDATS

Les candidats traiteront le sujet sur la copie qui leur sera fournie et veilleront à :

- respecter l'ordre des questions et reporter la numérotation sur la copie (numéro et lettre repère, le cas échéant : ex. : 6b) ;
- faire précéder les citations de la mention de la ligne ;
- composer des phrases complètes à chaque fois qu'il leur est demandé de rédiger la réponse ;
- respecter le nombre de mots indiqué. En l'absence d'indication, les candidats répondront brièvement à la question posée.

I. COMPRÉHENSION

1. a. Complete the family tree. Match each letter with a family member: THE AMERICAN GIRL - EVELIA - PEDRO - ROSA - PEDRO - LUCIO. Write the answers on your own exam paper.

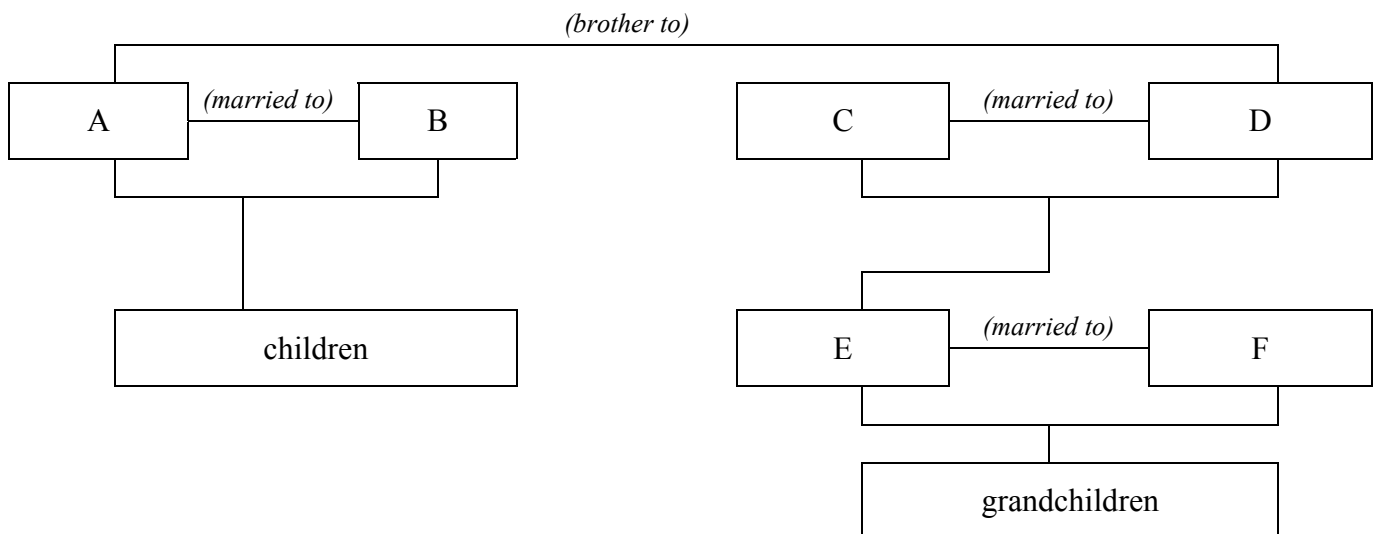

- b. Say in which country each of them (the American girl - Evelia - Pedro - Rosa - Pedro – Lucio) is living.
- c. Say in which country some of them have also lived.
2. Tell Rosa's story in your own words, using the following questions to help you:
- What did she attempt to do?
 - How far did she succeed and what happened to her?
 - What decision did she make afterwards?
3. Rosa's husband
- Pedro 'left for five years' (l. 36). Where did he go?
 - How did he manage over there? (20-30 words)

4. What can you say about the relationship between Lucio and his grandchildren? Justify your answer in your own words. (40-50 words)
5.
 - a. What does the author mean by '*It is an act of faith*' (l. 14)? (50-60 words)
 - b. What does '*the pain*' (l. 15) refer to?
6. The author's point of view
 - a. How does the author feel towards the Estradas?
Say why in your own words.
 - b. What are his views on '*the problem of illegal immigration*' (l. 44)?
7. Translate into French from '*Pedro couldn't. . .*' (l. 30) to '*. . . for seven months.*' (l.33)

II. EXPRESSION

Les candidats traiteront l'UN des deux sujets au choix (indiquer le nombre de mots).
(300 mots: +/- 10%)

Sujet 1:

Rosa's lawyer is pleading her case to have her released from jail. Write out the lawyer's defence.

OU

Sujet 2:

How necessary is it to speak the language of the host country in order to be integrated?